



ActivBoard 500 Pro Mobile System with EST-P1 projector

---

### THIS DOCUMENT CONTAINS SPECIFICATIONS FOR

ActivBoard  
Mobile Stand  
Projector

---

### DESCRIPTION

The ActivBoard 500 Pro with Dual-User Pen and Touch capability is available in 87" and 95" versions with integrated slim-line speakers and amplifier, ActivInspire Professional Edition, Promethean ActivOffice and Promethean Applications software. The Mobile System is easy to move and includes an Extreme Short Throw Projector.

---

### SYSTEM OVERVIEW

#### Installation

The installation of this product should be completed by a Promethean Certified Installer. Please visit [www.PrometheanWorld.com/ActivCare/installationtc](http://www.PrometheanWorld.com/ActivCare/installationtc). Components supplied and minimum specifications stated have been tested and are required for optimal performance. Use of components not supplied by Promethean or not meeting minimum specifications may impact performance and affect warranty. Contact your Promethean partner or visit [www.PrometheanKB.com](http://www.PrometheanKB.com) for more information

---

#### Warranty

For Promethean Warranty Information please visit: [www.PrometheanWorld.com/ActivCare](http://www.PrometheanWorld.com/ActivCare)

---

#### Support

Online Support for all Promethean Products available from: [www.PrometheanKB.com](http://www.PrometheanKB.com)

---

#### Complete System Weight (approx.)

ActivBoard 587 Pro including Projector 151kg (332.5lb)  
ActivBoard 595 Pro including Projector 159kg (350.1lb)

## INTERACTIVE WHITEBOARD SYSTEM

### UPGRADE AND ACCESSORY OPTIONS

#### ActivWand 50

Wireless, battery-free and extended reach input device for the ActivBoard – 540mm (21.2in) in length; “left click”, cursor and hover, just like a mouse

#### Mobile Stand Drawer

Optional\* drawer in the base of the System (includes lock and key), and can be used to store sets of ActivExpression, ActiVote, ActivSlate or the EST-P1 remote control. \*Mobile Stand drawer is included with the Mobile System in EU Region

#### Dry Erase Whiteboard

Optional dry erase whiteboard, can use 1 or 2 dry erase whiteboards per System

#### ActivBoard System Shelf

Storage for 1 laptop, with a maximum size of a standard 43cm (17in) laptop. Lockable System Shelf also available as an option

### TECHNICAL DRAWING SPECIFICATIONS

DIMENSION	87"	95"
ACTIVBOARD 'A'	2105 (82.9)	2412 (95)
IN USE 'B'	889 (34.6)	929 (36.6)
TRANSIT 'B'	738 (29.1)	778 (30.6)
IN USE 'C' ±10 (±0.4)	558 (23.2)	628 (24.7)
TRANSIT 'C' ±10 (±0.4)	438 (17.2)	478 (18.8)
HEIGHT 'D'	1960 - 2560 (77.2 - 100.8)	1990 - 2590 (78.3 - 102)
TURNING CIRCLE 'E'	2105 (82.9)	2412 (95)

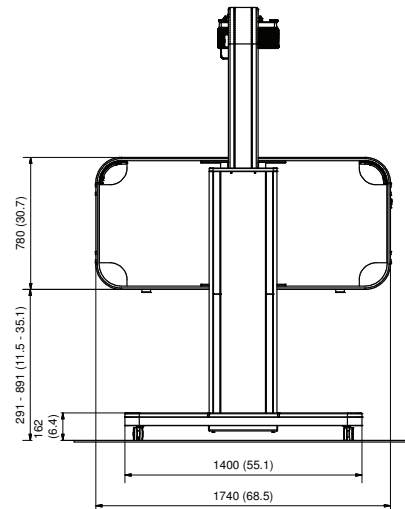
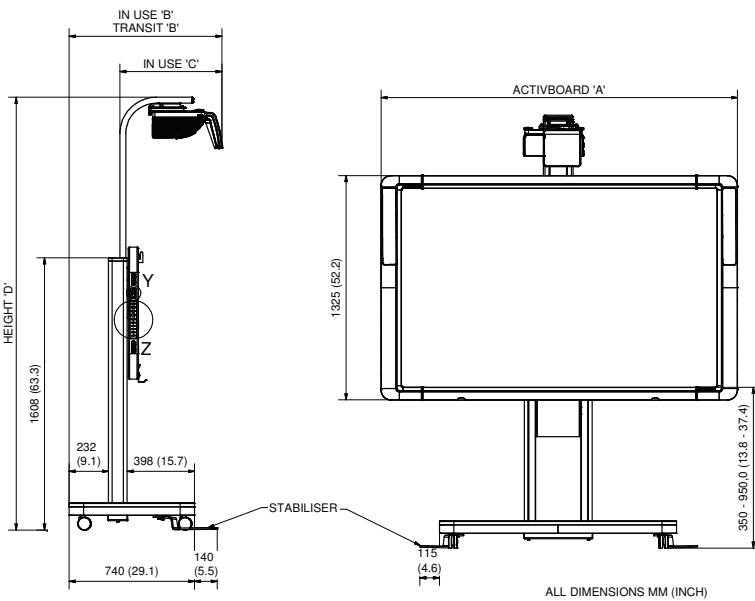

#### Z (1:4)

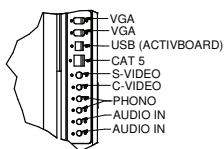

#### Y (1:2)

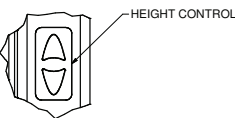

#### TRANSIT 'C'

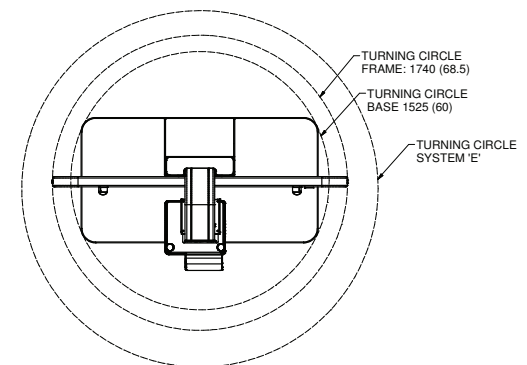

Promethean recommends the use of the Stabilisers when in use

Please note minimum turning circle, width and height dimensions as a consideration when moving the Mobile System from room to room

### ACTIVBOARD GENERAL SPECIFICATIONS

<b>Model</b>	ActivBoard 500 Pro Range
<b>Pen Internal Resolution</b>	2730 points (lines) per inch
<b>Pen Output Resolution</b>	200 points (lines) per inch
<b>Pen Tracking Rate</b>	200 inches per second providing a fast response to pen commands
<b>Pen Output Rate</b>	160 coordinate pairs per second (single user) 80 coordinate pairs per second (dual user)
<b>User Input</b>	Cordless battery-free pen incorporating tip switch and side switch for full mouse functionality (ActivPen) and touch
<b>Touch Resolution</b>	200 points (lines) per inch
<b>Touch Output Rate</b>	80 coordinate pairs per second
<b>Touch Response Rate</b>	10 ms
<b>Maximum Simultaneous Touches</b>	2 with ActivInspire (Minimum requirement of 1.5 ActivInspire Professional Edition) 4 with Windows 7
<b>Digitizing Technology</b>	Passive Electromagnetic and Capacitive sensing interface
<b>Power Requirement</b>	Mains Powered; 18V Power Supply Unit
<b>Connection to Computer</b>	USB 2.0, 1 x 3m USB 2.0 data cable supplied
<b>Connection to Peripherals</b>	2 x USB ports on left hand side
<b>Screen Surface</b>	Low Glare Melamine
<b>Certifications</b>	UL, CE, FCC
<b>Operating Temperature Range</b>	0°C to +40°C (32°F to 104°F)
<b>Storage Temperature Range</b>	-20°C to +60°C (-4°F to 140°F)
<b>Storage Humidity</b>	10% to 90% (non-condensing)
<b>Dual User Functionality</b>	<b>Pen:</b> 1 Instructor ActivPen and 1 Participant ActivPen can be used together in Dual-User Mode when using ActivInspire 1.5 Professional Edition and above <b>Pen and Touch:</b> 1 Participant ActivPen and simultaneous additional two-touch gesture supported when using ActivInspire 1.5 Professional Edition and above
<b>Single User Functionality</b>	<b>Pen:</b> 1 Instructor ActivPen <b>Touch:</b> Two-touch gesture supported when using ActivInspire 1.5 Professional Edition and above
<b>Integrated USB Sound</b>	Two integrated slim-line speakers and amplifier (with controls, inputs and outputs)
<b>Packed Contents List</b>	ActivBoard 587 Pro or ActivBoard 595 Pro, 2 Instructor ActivPens, 2 Participant ActivPens, 1 AMP PSU, Wall Mounting Brackets, User Guide, Access to ActivInspire Professional Edition, Promethean ActivOffice and Promethean Applications via download. (ActivInspire Professional Edition is also available on DVD on request), 1 x 3m USB data cable

### INTEGRATED USB SOUND SPECIFICATIONS

<b>Amplifier Power Output</b>	20W per channel RMS (<1% distortion)
<b>Controls</b>	Volume, Bass, Treble, on/off
<b>Amplifier Frequency Response</b>	40Hz to 18kHz +/-3dB (at 1W)
<b>USB Sound</b>	USB Sound supported for Minimum System Requirements stated
<b>Connectivity – Inputs (4)</b>	Stereo PC, Stereo CD/DVD, Mono Auxiliary, Microphone to PC
<b>Connectivity – Outputs (2)</b>	2 Stereo
<b>Power Requirement</b>	18V 5 Amp

### ACTIVBOARD SPECIFICATIONS

Model	ActivBoard 587 Pro	ActivBoard 595 Pro
<b>ActivBoard Size</b>	87in	95in
<b>Resolution</b>	14600 x 9200	17200 x 9200
<b>Screen Formats</b>	16:10	16:9
<b>Overall Dimensions</b>	2105mm x 1329mm (82.9in x 52.3in)	2336mm x 1329mm (92in x 52.3in)
<b>Active Area Dimensions</b>	1865mm x 1175mm (73.4in x 46.3in)	2095mm x 1175mm (82.5in x 46.3in)
<b>Active Area Diagonal</b>	2196mm (86.5in)	2394mm (94.3in)
<b>Actual Image Diagonal</b>	2193mm (86.4in)	2392mm (94.2in)
<b>Board Weight</b>	40kg (88lb)	48kg (106lb)
<b>Packed Weight</b>	57kg (126lb)	65kg (143lb)
<b>Packed Dimensions</b>	2270mm x 1500mm x 110mm (89.4in x 59.1in x 4.3in)	2572 mm x 1495mm x 110mm (101.3in x 58.9in x 4.33in)

### MINIMUM COMPUTER REQUIREMENTS

<b>Operating Systems</b>	Windows XP SP3 and above (XP/Vista/7); Mac OSX 10.4.11 – 10.6.4 (Tiger/Leopard/Snow Leopard); Linux Ubuntu 9.10 or 10.04; Debian Lenny; Linex Colegios 2010; Linkat 3; ALT_Linux (Russia)
<b>PC</b>	2.0 GHz Intel Core 2 Duo or faster for HD-quality videos, 1 GB of RAM is required to play HD-quality videos, 1024 x 768 resolution, 1.5 GB of Free Disk Space
<b>Mac</b>	2.0 GHz Intel Core 2 Duo, 512 MB of RAM, 1024 x 768 resolution, 3.0 GB of free disk space
<b>Linux</b>	2.0 GHz Processor or faster for HD-quality videos, 1 GB of RAM is required to play HD-quality videos, 1024 x 768 resolution, 1.5 GB of free disk space

ActivBoard Systems/Boards SS 11/11 V2.0 US

©2011 Promethean Limited. All rights reserved. Promethean Ltd. is owner of a number of trademarks in several jurisdictions across the world. Any third-party product and company names are mentioned for identification purposes only and may be trademarks of their respective owners. <sup>1</sup>Applicable Terms and Conditions for warranty and support available at [www.PrometheanWorld.com/ActivCare](http://www.PrometheanWorld.com/ActivCare). All dimensions +/- 5mm (0.2in). All weights +/- 0.9kg (2lb). Product Specifications are subject to change without notice. [www.PrometheanWorld.com](http://www.PrometheanWorld.com)

## MOBILE STAND SPECIFICATIONS

<b>Projector Model</b>	Extreme Short Throw
<b>Height Settings</b>	Height-adjustable mount, with 600mm (23.6in) of adjustment from 350mm (13.8in) to 950mm (37.4in) ± 50mm (1.9in). Top and bottom limit stops are fitted if the full range of movement is not required/appropriate. Height adjustment is powered by an electrical motor and is operated using a switch on the side of the stand
<b>Actuator Specification</b>	<p>Input Voltage: 24VDC            Max Load: 750N            Static Load: more than 750N            Speed: 30mm/s (no load), 20mm/s (750N)            Stroke Length: 600 ± 2mm            Retracted Length: 795 ± 2mm            End Mounting Dimension: H Type, ø10.1 hole, 6.3mm Slot            Limit Switch: Built-in            Duty Cycle: S2-10min            Temperature: -26° to 65°C            IP Degree: IP54            AC-DC Adaptor:            Input Voltage: 100 ~ 240VAC            Output Voltage: 29VDC            Current: 2Amp (4Amp protected)            Cable and Plug: 1.5m, IEC Plug</p>
<b>Projector Boom</b>	Aluminum boom arm, extends 740mm (29.1in) from the back of the System. Projector Boom adjusts with the height of the ActivBoard reducing the need for specific re-calibration following height adjustment
<b>Mobile Base Dimensions</b>	1400mm x 740mm (55.1in x 29.1in)
<b>Room Height Requirements</b>	Minimum 2562mm (100.9in) for full range operation
<b>Door Size Requirements</b>	Minimum door height clearance of 1962mm (77.2in) and door width clearance of 775mm (30.5in).
<b>Minimum Turning Circle Requirement</b>	See Technical Drawing Specifications at the end of this document
<b>Integrated Power Management</b>	For ActivBoard, Mobile Stand and Projector. There will be one lead from the Mobile System to plug into a wall socket
<b>Frame Weight (approx.)</b>	Frame only: 100kg (220.5lb); excl. board, projector, cabling and accessories
<b>Connectivity Panel</b>	Connectivity panel with inputs for 2 x fully wired VGA (to support VESA DDC) plus 3.5mm stereo jack audio inputs, USB-B input (for ActivBoard), S-Video, composite video plus auxiliary audio jack inputs, Cat 5e Ethernet input. Connectivity panel is mounted to the left hand-side of the Support Frame (when facing the system)
<b>Cables</b>	Cable assembly includes: 2 x 3.6m (11.8ft) VGA panel mount (fully wired to support VESA DDC), 3.6m (11.8ft) S-Video panel mount, 3.6m (11.8ft) composite video panel mount, 3.6m (11.8ft) Ethernet panel mount, 2.5m (8.2ft) USB patch cable (to connect computer to face plate). 2.3m (7.5ft) right angle stereo jack to panel mount jack socket, 2.3m (7.5ft) right angle stereo jack to panel mount phono pair, for PC audio input (to connect computer to face plate). 2m (6.6ft) VGA cable provided in the projector box (to connect the computer to the face plate)

CONTINUED ON NEXT PAGE

ActivBoard Systems/Boards SS 11/11 V2.0 US

©2011 Promethean Limited. All rights reserved. Promethean Ltd. is owner of a number of trademarks in several jurisdictions across the world. Any third-party product and company names are mentioned for identification purposes only and may be trademarks of their respective owners. <sup>1</sup>Applicable Terms and Conditions for warranty and support available at [www.PrometheanWorld.com/ActivCare](http://www.PrometheanWorld.com/ActivCare). All dimensions +/- 5mm (0.2in). All weights +/- 0.9kg (2lb). Product Specifications are subject to change without notice. [www.PrometheanWorld.com](http://www.PrometheanWorld.com)

## MOBILE STAND SPECIFICATIONS (CONTINUED)

### Pack Weights & Dimensions

**Box 1 of 4:** 13kg (28.7lb)  
Dimensions: 217mm x 1427mm x 467mm (8.54in x 56.18in x 18.39in)  
Contents: Boom

**Box 2 of 4:** 28kg (61.7lb)  
Dimensions: 182mm x 1652mm x 442mm (7.2in x 65in x 17.4in)  
Contents: Spine

**Box 3 of 4:** 22kg (48.5lb)  
Dimensions: 128mm x 1782mm x 822mm (5.04in x 70.16in x 32.36in)  
Contents: Frame

**Box 4 of 4:** 42kg (92.6lb)  
Dimensions: 202mm x 1442mm x 782mm (7.95in x 56.77in x 30.79in)  
Contents: Mobile Base

## PROJECTOR SPECIFICATIONS

<b>Model</b>	EST-P1 (DLP)
<b>Native Resolution</b>	WXGA (1280 x 800)
<b>Compressed Resolution</b>	up to 1080i
<b>Typical Colors</b>	16.77 million colors
<b>Brightness (ANSI lumens)</b>	2200 ANSI (normal) 2500 ANSI (high)
<b>Contrast Ratio</b>	2000:1
<b>Noise Level</b>	27dB (normal) 31dB (high brightness mode)
<b>Dimensions (w x d x h)</b>	354mm x 319mm x 157mm (13.9in x 12.6in x 6.1in) not including lens 354mm x 411mm x 219mm (13.9in x 16.1in x 8.6in) including lens
<b>Weight</b>	9kg (19.8lb)
<b>Aspect Ratio</b>	16:10 (native), 4:3, 16:9
<b>Power Consumption</b>	290W (<1W standby)
<b>Device Type</b>	DLP Technology
<b>Focus</b>	Manual Focus
<b>Zoom</b>	N/A
<b>Focal Length</b>	F=2.4
<b>Projection Distance</b>	0.39m ~ 0.56m (15in ~ 22in)
<b>Projection Screen Size</b>	1.98m ~2.79m (78in ~ 110in)
<b>Lamp Type</b>	220W lamp
<b>Lamp Life</b>	6000hrs (normal), 4000hrs (high)
<b>Keystone Correction</b>	Vertical: max ±15°
<b>Operating Temperature</b>	5°C ~ 35°C (41°F ~ 95°F)
<b>Power Supply Voltage</b>	100 - 240V AC, 50/60Hz
<b>Horizontal Scan Rate</b>	15Hz ~ 90kHz
<b>Vertical Scan Rate</b>	43Hz ~ 85Hz

CONTINUED ON NEXT PAGE

ActivBoard Systems/Boards SS 11/11 V2.0 US



©2011 Promethean Limited. All rights reserved. Promethean Ltd. is owner of a number of trademarks in several jurisdictions across the world. Any third-party product and company names are mentioned for identification purposes only and may be trademarks of their respective owners. <sup>1</sup>Applicable Terms and Conditions for warranty and support available at [www.PrometheanWorld.com/ActivCare](http://www.PrometheanWorld.com/ActivCare). All dimensions +/- 5mm (0.2in). All weights +/- 0.9kg (2lb). Product Specifications are subject to change without notice. [www.PrometheanWorld.com](http://www.PrometheanWorld.com)

## PROJECTOR SPECIFICATIONS (CONTINUED)

<b>Computer Compatibility</b>	IBM PC and Compatibles; Apple Macintosh, iMac, and VESA Standards WSXGA+ (1,680 x 1,050), WXGA+ (1,440 x 900), WXGA (1,280 x 800, 1,280 x 768), UXGA (1,600 x 1,200), SXGA+ (1,400 x 1,050), SXGA (1,280 x 1,024), XGA (1,024 x 768), SVGA (800 x 600), VGA (640 x 480)
<b>Video Compatibility</b>	NTSC (3.58/4.43), PAL (B/D/G/H/I/M/N), SECAM (B/D/G/K/K1/L), HDTV (720p, 1080i, 1035i), EDTV (480p, 575i), SDTV (480i, 576i)
<b>Inputs/Outputs</b>	D-sub 15 (RGB) x 2 D-sub 15 (Monitor out) x 1 HDMI V1.3 only for Video x 1 S-Video x 1 Composite Video (RCA) x 1 USB control x 1 Networking LAN (RJ45) x 1 RS-232C (D-sub 9) x 1
<b>Color</b>	Silver
<b>Security</b>	Kensington Lock, Security cable bar option, pin code security, remote control operated only
<b>On-screen Menu</b>	Arabic, Chinese (Simplified), Chinese (Traditional), Czech, Dutch, English, Finnish, French, German, Greek, Hungarian, Italian, Japanese, Korean, Norwegian, Polish, Portuguese, Russian, Spanish, Swedish, Thai, Turkish
<b>Advanced Features</b>	Filter-less 3D Ready Crestron RoomView Express Quick Lamp Access Direct power on/off Closed Caption
<b>Packed Contents List</b>	Projector, Power cord, computer cable (D-sub15 – D-sub15), wireless remote, owner's manual (CD - ROM & Quick Start Guide)
<b>Pack Weights and Dimensions</b>	<b>Box 1 of 1:</b> 13.5kg (29.7lb) Dimensions: 572mm x 496mm x 310mm (22.5in x 19.5in x 12.2in) Contents: Projector

ActivBoard Systems/Boards SS 11/11 V2.0 US



©2011 Promethean Limited. All rights reserved. Promethean Ltd. is owner of a number of trademarks in several jurisdictions across the world. Any third-party product and company names are mentioned for identification purposes only and may be trademarks of their respective owners. <sup>1</sup>Applicable Terms and Conditions for warranty and support available at [www.PrometheanWorld.com/ActivCare](http://www.PrometheanWorld.com/ActivCare). All dimensions +/- 5mm (0.2in). All weights +/- 0.9kg (2lb). Product Specifications are subject to change without notice. [www.PrometheanWorld.com](http://www.PrometheanWorld.com)